

BALL VALVE # BV-600L

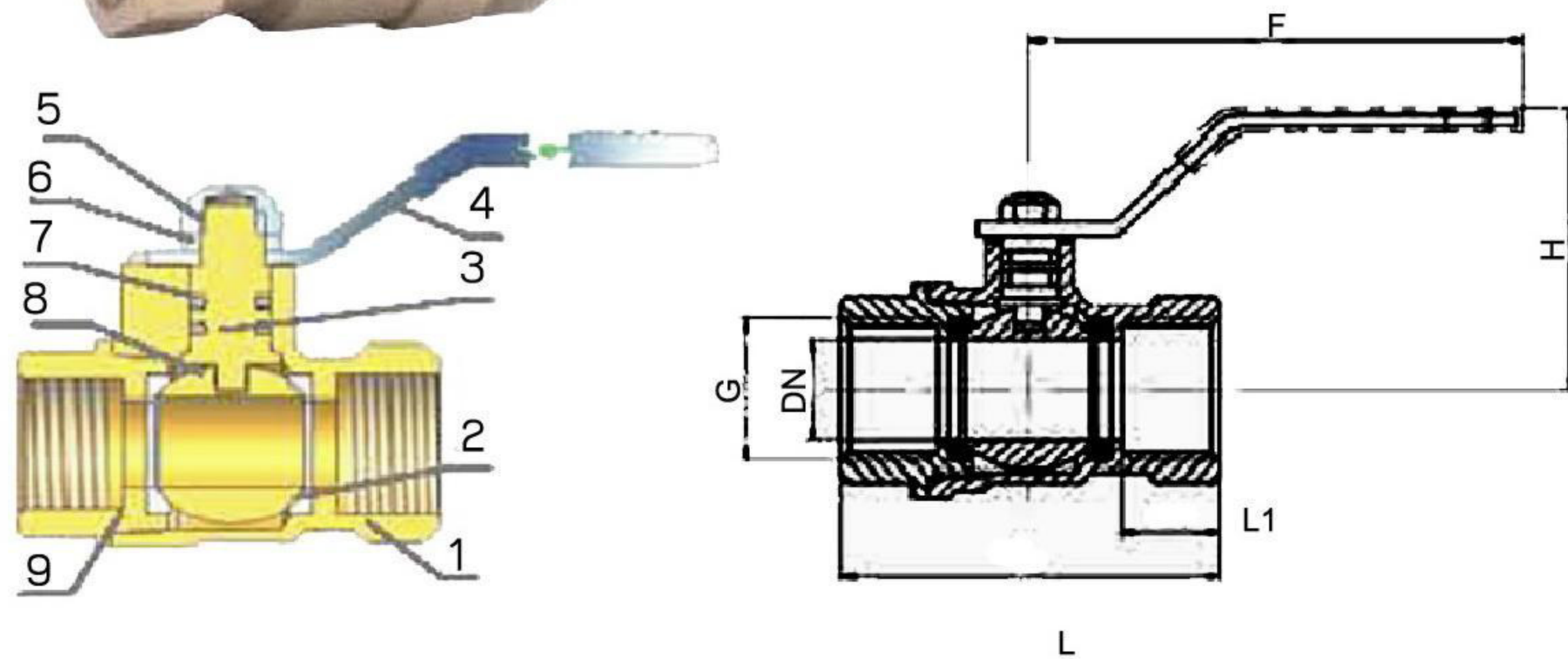

PRESSURE & TEMPERATURE LIMITATIONS FOR PN RATED VALVE

DN	Working Pressure & Temperature	Test Pressure Seat (Air)
1/4" - 3/8"	400 Psi. -10°C to 100°C	54 Psi.
1/2" - 2"	600 Psi. -10°C to 100°C	80 Psi.

NO.	COMPONENT	MATERIAL
1	Body	Forged Brass
2	Seat	PTFE
3	Stem	Forged Brass
4	Handle	Steel *Zinc plated
5	Handle Nut	Steel
6	Gland Packing	Brass
7	Packing	PTFE
8	Ball	Forged Brass (Hard chromuim plated)
9	Cap	Forged Brass

Size	DN	L	L1	H	F
1/4"	8	41	10.5	43	80
3/8"	10	43	10.5	43	80
1/2"	15	50	13	42.5	91
3/4"	20	61.5	15	50.5	91
1"	25	72	17	63	104
1.1/4"	32	82.5	19	69	104
1.1/2"	40	94.5	21	73.5	160
2"	50	106	22	81	160