

## GATE VALVE # GV - 1101

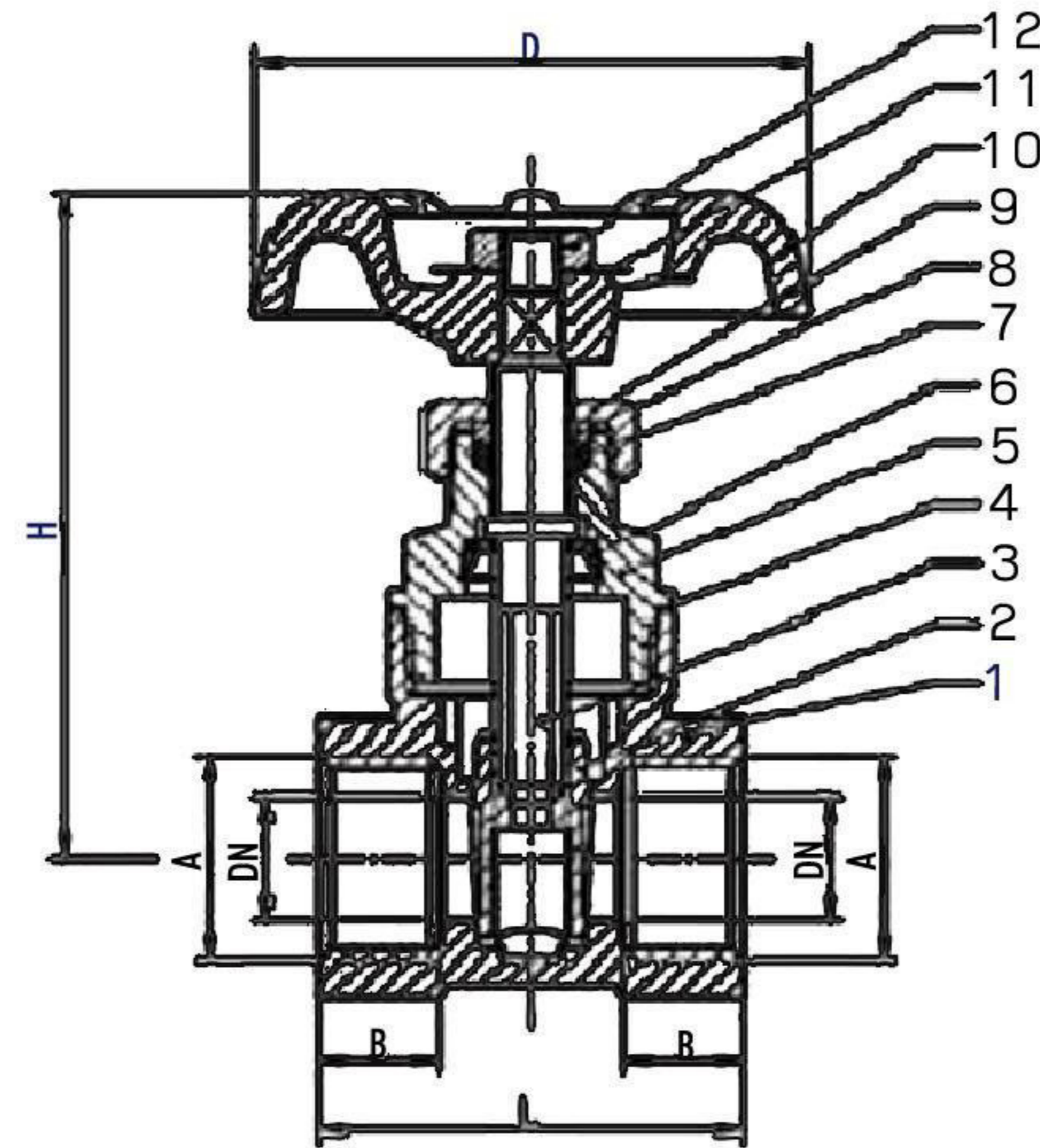

- 1. Nominal Pressure : 200Psi.W.O.G
- 2. Suitable Medium : Water, Seawater, Non-causticity liquid, Saturated Steam
- 3. Working Temperature : -20°C to 170°C
- 4. Thread : Bs 21

NO.	COMPONENT	MATERIAL
1	Body	Forged Brass
2	Wedge	Forged Brass
3	Stem	Forged Brass
4	Washer	PTFE
5	Bonnet	Forged Brass
6	Screw	Forged Brass
7	Packing	PTFE
8	Gasket	Brass
9	Hex nut	Forged Brass
10	Hand wheel	Cast iron
11	Name plate	Aluminium plate
12	Nut	Steel (Zinc plated)

Size	DN	A	B	D	H	L
1/2"	15	G1/2	11.5	53	67.5	41
3/4"	20	G3/4	11.5	53	75	44
1"	25	G1/2	13	57.5	80	51
1.1/4"	32	G1.1/4	13	72	96.5	53
1.1/2"	40	G1.1/2	15.5	72	111.5	58.5
2"	50	G2	16.5	78	126.5	64.5
2.1/2"	65	G2.1/2	18	97	156	76.5
3"	80	G3/4	19	108	180	77.5
4"	100	G4	21.5	126	226	91.5